



**Price Electric
Cooperative**

A Touchstone Energy® Cooperative 

Service Requirements



Contact Information

Price Electric Cooperative
Operations Department
W6803 Springs Dr · PO Box 110
Phillips, WI 54555
715.339.2155 | 800-884-0881



Price Electric Cooperative



A Touchstone Energy® Cooperative 

Table of Contents

Section 1—General.....	3
Purpose of Service Requirements.....	3
Member Wiring, Code Compliance and Inspection.....	4
Application for Service.....	5
Increased Loads.....	6
Continuity and Quality of Service.....	6
Resale of Energy.....	6
Section 2—Types of Service and Voltages.....	7
Section 3—Line Extensions.....	8
Line Extensions on Private Property.....	8
Line Extensions on Other than Private Property.....	8
Overhead Conductor Clearances.....	8
Section 4—Services.....	9
Point of Service.....	9
Service Location.....	9
Temporary Service.....	10
Relocation of Services.....	10
Section 5—Cooperative Equipment on Member Premises.....	11
Sealing of All Equipment.....	11
Theft of Service.....	11
Section 6—Meter Locations.....	12
Types of Services.....	13
Section 7—Member Generating Equipment.....	31
Appendix.....	32
Approved Equipment List.....	35
Glossary.....	37



**Price Electric
Cooperative**

A Touchstone Energy® Cooperative 

Section 1—General

Purpose of Service Requirements

The following information, detailing the rules and regulations of the Price Electric Cooperative (Cooperative) concerning electric service installations, is published for the convenience of the Cooperative's members, their architects and contractors. These rules are in addition to the Wisconsin Administrative Code, the National Electrical Code, the National Electric Safety Code and any other regulations that may apply. The Cooperative reserves the right to make revisions to these rules whenever changes in the article, legal requirements, or other circumstances make it advisable. These rules are intended for standard equipment installations. When, because of the physical limitations of the premises, it is impractical to follow them, the Cooperative shall be consulted for permissible modifications. The information contained herein does not specifically cover the requirements of the Cooperative's rate schedules, line extension policy, or general rules; the Cooperative should be consulted for information concerning these matters.

The Cooperative may refuse or discontinue service if a member does not comply with these rules, however, the member will first be notified and afforded a reasonable opportunity to comply. Service may be discontinued without prior notice when hazardous conditions exist on the member's premises.



Price Electric Cooperative

A Touchstone Energy® Cooperative 

Member Wiring, Code Compliance and Inspection

All wiring shall be done in accordance with requirements of the Wisconsin Administrative(electrical)Code, the National Electrical Code, the Cooperative's rules and other local requirements which may apply.

The Cooperative will not inspect the member's wiring or equipment beyond the metering point or cabinet for compliance with the applicable codes.

In new wiring installations or when changes in existing wiring are made which require the removal of meters or the disconnection of service, the Cooperative shall not connector resume service until the contractor or person doing the wiring furnishes the Cooperative with a Wiring Compliance Statement showing proof of compliance with the Wisconsin Administrative(electrical) Code and the National Electrical Code.

Accounts that have been inactive for 12 months shall require an updated Wiring Compliance Statement before the meter is installed.

The Cooperative will not interpret the electrical code. Questions concerning code interpretation should be referred to the local or state electrical inspector. The contact information is:

State of Wisconsin/DILHR Industrial Safety & Building Division
201 East Washington Avenue
PO Box 7969
Madison, WI 53707
Phone:(608) 266-3064

The Cooperative will inspect for compliance with its requirements and may refuse or discontinue electric service if its requirements are not complied with or if a hazardous condition exists.

Cooperative crews setting meters or connecting new services for single-phase one-family dwellings test for infinite resistance, back feed, shorted and grounded entrance cables at the meter socket load terminals. It is recommended that the service disconnect switch be left open to avoid the indication of connected load at the meter base.

Note: Cooperative crews will not enter a building to open or inspect the service disconnect switch.



Price Electric Cooperative

A Touchstone Energy® Cooperative



Application for Service

Guidelines for applying for service are outlined below.

A. Application for Membership

Application for membership must be completed. All service extensions require that electric service continue in force for five years from the date service is made available by the Cooperative.

B. Engineering Assessment

An engineering assessment is necessary to determine the location of the service routing and termination point.

C. Construction Fees

PEC personnel will calculate the service installation fees after the site visit. All fees must be paid prior to the installation of the service.

If construction takes place between November 1 and April 1, additional winter charges may be applied.

In the event that another member or members connect to the line extension within five years of the date the service was originally connected, the original member will be reimbursed proportionately for the aid to construction fee as long as he retains ownership of the property for which the fee was paid.

D. Easements and Government Requirements

Easements required from the applicant and from other parties shall be obtained by the applicant at no cost to the Cooperative. The Cooperative may prepare the easements for the applicant's signature. Any permits, inspections, surveys, etc., required before construction which require a fee, shall be paid for by the applicant requesting service.

E. Line Clearance (Tree & Brush Removal)

Applicant is responsible for initial clearing of right-of-way on applicant's property as outlined in the Cooperative's Right-of-Way Clearing Guidelines, Methods, and Procedures, required for line construction.

F. Completion of Service Entrance Wiring

The electrician or property owner (pursuant of Chapter SPS 316.950 (2) of the Wisconsin Administrative Code) shall provide notification to the Cooperative of compliance with local and/or state electrical codes before a service will be connected.

**This will be in the form of a wiring compliance statement furnished by Price Electric Cooperative and completed by the contractor, master electrician or homeowner doing the wiring.

G. Job Scheduling

Prior to job scheduling by the Cooperative, the following items, where applicable, are required:

- All paperwork has been submitted and fees paid.
- Line installation route has been cleared of any brush, stumps, dirt piles, and debris.



Price Electric Cooperative

A Touchstone Energy® Cooperative 

Increased Loads

In cases where member's load requirements have changed, necessitating a change of meter or increased transformer or conductor sizing, the Cooperative shall be given reasonable notice so that it may provide a meter, service drop, and transformer of the proper capacity. Delays, poor service or a burned-out meter or transformer will thus be avoided. The Cooperative may charge for the replacement cost of damaged Cooperative equipment.

Continuity and Quality of Service

The Cooperative will use reasonable care to provide an uninterrupted and regular supply of service; but shall not be liable for any loss, injury, or damage resulting from interruptions, deficiencies or imperfections of service not due to willful default or negligence on its part.

The Cooperative shall have the right to cause service to any member to be interrupted or limited at any time, without liability, by automatic devices or otherwise, when in the judgment of the Cooperative such interruption or limitation is necessary or desirable due to emergency conditions.

All motors, appliances or equipment connected to the Cooperative's system shall be so designed, installed, and operated so as not to cause interference to other Members' service equipment or to impede the Cooperative in maintaining proper system conditions.

It shall be the responsibility of the member to provide motor protection for under voltage, overcurrent, short circuit, and back feed.

The Cooperative may also curtail or temporarily interrupt the member's electric service in order to make repairs, replacements or changes to the Cooperative's facilities, either on or off the member's premises. The Cooperative will, whenever practical, give notice to members who might be seriously affected by such suspension or curtailment of service.

It is intended that the voltage provided to the member complies with the requirements of the Wisconsin Administrative Code. This code allows voltage transients of an infrequent nature, which may adversely affect the operation of certain sensitive equipment. Prevention of undesirable operation of sensitive equipment caused by these transients is the responsibility of the member.

Resale of Energy

Services shall be for the members use only and may not be resold, re-metered or otherwise disposed of by the member to lessee, tenants or others, except with the consent of the Cooperative in accordance with the Cooperative's appropriate rate schedule permitting such use of service. This does not prohibit the installation of test or check meters for informational purposes.



Price Electric Cooperative

A Touchstone Energy® Cooperative 

Section 2—Types of Service and Voltages Available

The Cooperative furnishes 60-Hertz(cycles) alternating current, single and three-phase, at various voltages, but not all types of services are available in every locality.

The type of service available to the member is ordinarily determined by one or more of the following conditions:

- Character and size of load to be served.
- Temporary or permanent.
- Underground or overhead service.

Types of Service and Nominal Voltage Furnished:

- Single-phase, 120/240 volts, three wire
- Three-phase, 277/480 or 120/208 volts, four wire wye

Electric service at other voltages and capacities may be obtained under special circumstances.

Members' requests for additional services or services which do not conform to these rules shall be treated as "special facilities". The member is obligated, in accordance with the Cooperative extension rules, for any added cost involved. The Cooperative reserves the right to deny special facilities.



**Price Electric
Cooperative**

A Touchstone Energy® Cooperative 

Section 3—Line Extensions

Line Extensions on Private Property

Extension of the Cooperative's distribution lines on to property of the member to be served will be made in accordance with the Cooperative's line extension policy, membership application, easement and requirements.

These requirements provide, among other things, that the Cooperative will own and be responsible for the maintenance and operation of such lines and shall have the right of access at all reasonable times for construction, reconstruction, tree trimming, maintenance inspection, rebuilding, outage restoration, maintenance and operation of lines and equipment with the right to remove poles and other equipment upon discontinuance of service.

Price Electric Cooperative will prepare all necessary easements along the route selected. The member requesting service shall be responsible for obtaining all signatures and all associated easement costs. Permanent survey stakes identifying property lines may be required by the Cooperative prior to installation of facilities.

When installed at member request, the member shall grant rights-of-way satisfactory to the Cooperative for the installation and maintenance of the electric facilities. The right-of-way as designated by the Cooperative shall be cleared of trees and other obstructions by or at the expense of the member and in accordance with the Cooperative's Right-of-Way Clearing Guidelines, Methods and Procedures Handbook.

Line Extensions on Other than Private Property

The Cooperative shall obtain all licenses or permits that are necessary for right- of-way along the route which are not on private right-of-way. Examples are highway permits, railroad licenses, etc. Associated permit and license fees are the obligation of the member applying for service.

Overhead Conductor Clearances

Contact the Cooperative prior to new construction, repairs, or renovations to member-owned existing structures near or beneath overhead wires.



**Price Electric
Cooperative**

A Touchstone Energy® Cooperative 

Section 4—Services

The Cooperative will extend service to members as promptly as practical, consistent with prevailing conditions and will always cooperate with contractors and members in order to provide proper service connections. It is requested that application for service be made as early as possible to permit the Cooperative to schedule its work. Where there is a question concerning the meaning or application of the Cooperative rules, unnecessary delays or expense may be avoided by consulting the Cooperative in advance of construction. Members, their architects, engineers, or contractors shall consult the Cooperative concerning entrance and meter locations; service voltage; and the type, phase, and voltage of motors and other equipment. Commercial services shall supply load calculation information for transformer, service, and metering selection. They shall consult the Cooperative concerning the installation of special circuits for separate metering or load control to meet the rate requirements of the Cooperative and permit adequate service.

Point of Service

The energy supplied by the Cooperative changes ownership at the point of service. This is the location where the member's wiring starts and the Cooperative's ends. The overhead point of service is where the Cooperative attaches its service drop to the building, structure or meter pole. The underground point of service is at the metering location that's either attached to a building, structure, meter pole, or at a meter pedestal.

The Cooperative wires terminate on the line side wire terminals of the meter socket unless on an underground service, at the service entrance on an overhead service and on a polyphase service, (except a three-Phase, Four-Wire Delta) the point of service is at the metering equipment (current transformers).

Service Location

The location of the member's service entrance shall in all cases be designated by the Cooperative. The Cooperative or its representatives shall make all connections to its lines, and in no case shall these connections be made by other than Cooperative representatives. To avoid misunderstanding and additional expense, the Cooperative shall be consulted concerning all new service connections.

No new service will be connected without a means of an external disconnect.



Price Electric Cooperative

A Touchstone Energy® Cooperative 

Temporary Service

Temporary service structures shall be adequately supported and of a sufficient height to permit compliance with required code clearances. The Cooperative will allow construction of a 200-amp maximum temporary service, upon request. The temporary service will be installed as close as practical to the nearest structure or within ten feet of a pad-mounted transformer, and for a period not to exceed twelve months from connected date.

The structure, including bracing, shall be clear of the underground service trench by a minimum of four feet. Applicant shall pay, in advance of construction, a temporary service fee, as per Rate Tariff Schedule T.

Relocation of Services

Any changes requested by a member at the point of service termination or removal and reinstallation or service conductors will be billed to the member.



Price Electric Cooperative

A Touchstone Energy® Cooperative 

Section 5—Cooperative Equipment on Member Premises

The Cooperative shall have the right to install, inspect and maintain its equipment on the member's premises as is necessary to furnish proper service. All such equipment shall remain Cooperative property, and the Cooperative shall have the right to remove it upon discontinuation of service. The member will allow inspection of Cooperative equipment within member equipment, such as, but not limited to, the meter base or current transformer. The member shall be responsible for damages and losses resulting from interference or tampering with such equipment caused or permitted by the member. If the Cooperative equipment is interfered with or damaged, the Cooperative may require the member to change his wiring, at his own expense, to permit the installation of other Cooperative equipment or to permit the relocation of Cooperative equipment to avoid further interference or damage.

Sealing of Equipment

Meters and all associated metering equipment, service termination boxes, wire raceway, and service entrance switches containing unmetered conductors are sealed by the Cooperative. This equipment must be designed with provisions for seals or locks as specified by the Cooperative. Cooperative management may grant permission to a master electrician remove a meter seal for maintenance of member equipment.

Unauthorized removing of Cooperative seals is unlawful and may result in billing for the investigation and replacement of the seal, as well as criminal prosecution.

Theft of Service

The Cooperative will investigate the possibility of theft of service whenever tampering with meter seals, meters, service conductors, and service connections is reported or detected. Only Cooperative authorized and qualified persons are permitted to make connections to Cooperative lines.

If the investigation determines that electricity is being diverted, the service may be disconnected.

Prior to restoration of service the member's service entrance equipment shall be locked or sealed in accordance with Cooperative requirements and satisfactory arrangements will have been made for payment of the estimated amount of unmetered electricity.

Theft of service may result in criminal prosecution.



**Price Electric
Cooperative**

A Touchstone Energy® Cooperative 

Section 6—Meter Locations

Members shall provide a suitable location for meters and associated equipment determined by and without charge to the Cooperative.

Meters shall be installed in an accessible location to enable them to be safely read, inspected and tested at reasonable times with a minimum of inconvenience to the member and Cooperative.

Multiple meter installations served from a single entrance shall be grouped at a location approved by the Cooperative.

All single-phase and polyphase meter installations shall be located outside.

Meters shall not be installed in patio, porch, deck or carport areas or areas likely to be enclosed in the future.

At earth-bermed buildings that do not have an exposed side suitable for the meter location, the service shall be terminated at a meter pedestal.

Meters shall not be installed on mobile homes.

The meter location shall be on a solid structure free from vibration and possible mechanical damage.

The member shall be responsible for providing protection for the meter(s) from damage caused by falling ice, snow or other objects. In locations where the meter is not protected by roof overhang, the member shall provide a protective shield. The clear space in front of or around meter bases and instrument transformer cabinets shall be maintained at a minimum of 4 feet horizontal and 6 feet 6 inches vertical clearance. Two feet of horizontal clearance on either side shall also be provided.

If changes are made to the member's premises making the existing meter location unsafe or inaccessible for reading and testing, the member shall be required to make changes so that the meter may be located to comply with these rules. Failure of the member to correct the unsafe or inaccessible concerns within a reasonable length of time after written notification shall be considered as noncompliance with these rules. The Cooperative reserves the right to discontinue electric service until the member has changed the unsafe or inaccessible as outlined above.



Price Electric Cooperative

A Touchstone Energy® Cooperative 

Types of Services

200-Amp Underground Service Meter Pedestal with Main Breaker

- A. The Cooperative shall furnish and install the line conductors. Where the Cooperative's wires will be covered by concrete or blacktop, the member shall provide conduit to extend at least 3 feet beyond the edge of the concrete or blacktop. Adequate conduit will be determined by the Cooperative and the conduit and trench must be inspected by the Cooperative prior to backfilling. Failure to do so could cause complications associated with the service installation and/or additional expense.
- B. The member has the option to purchase a Cooperative-approved 200-amp meter pedestal with main breaker from the Cooperative or independently. If purchased from the Cooperative, the Cooperative will install the pedestal, at member expense. If purchased elsewhere, the member is responsible for installation to the Cooperative's specifications.

Pedestal style meter sockets shall be required for underground to underground 200-amp installations. This includes up to four-meter positions.

Meter pedestals shall be adequately supported to maintain the meter socket in a level and plumb position.

- C. On group installations, each meter socket and service switch shall be permanently marked identifying the location to be served. The location being served shall be identified in the same manner.
- D. If the member purchases a Cooperative approved 200-amp meter pedestal with main breaker from the Cooperative, the Cooperative-approved ground rods will be provided. If the meter pedestal is purchased independently, the rods must be as well. The rods shall be two 5/8" copper clad steel ground rods and approved clamps. Ground rods and grounding conductors shall not be installed in front of the meter pedestal or within 2 feet of the underground cable route. If the pedestal and rods are both purchased from the Cooperative, the Cooperative will install the rods and clamps. If purchased elsewhere, the member is responsible for installation to Cooperative specifications.
- E. The grounding electrode conductor from the ground rods shall not be spliced or terminated in the meter socket or utility portion of the pedestal. The top of the ground rods should be at least 12" below grade level. Ground wire shall be minimum 4 AWG copper wire.
- F. Member shall furnish and install load conductors between the meter pedestal and the member's breaker panel.
- G. Adequate space shall be provided for removal of the meter pedestal cover when concrete or blacktop covers the area in front of the meter pedestal.
- H. Wiring shall be installed in compliance with state electrical code and any local requirement.



**Price Electric
Cooperative**

A Touchstone Energy® Cooperative

200-Amp Underground Service Meter Pedestal with Main Breaker

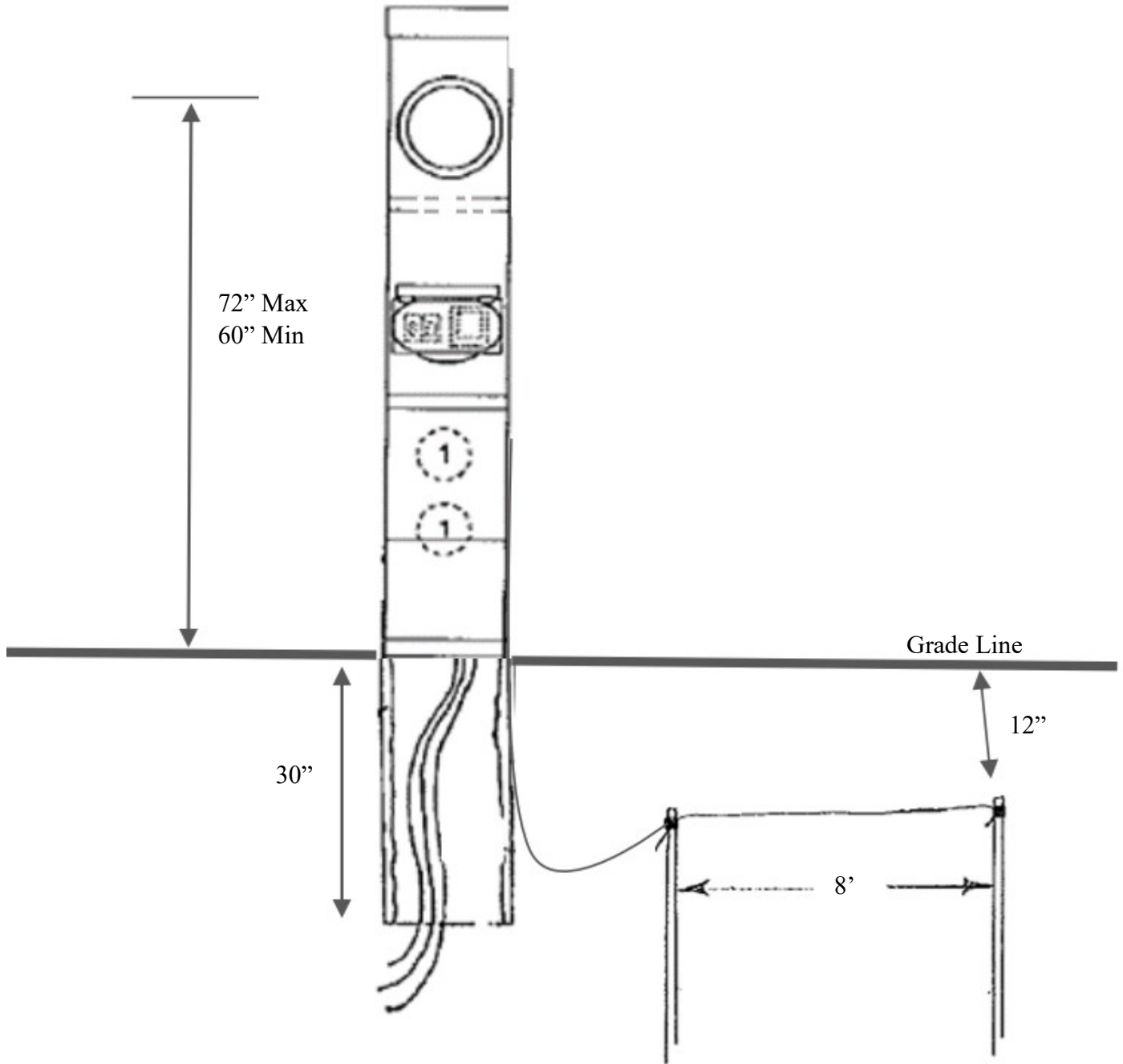



Price Electric Cooperative

A Touchstone Energy® Cooperative 

200-Amp Overhead Service on Building/Overhead Pipe Mast

- A. The member has the option to purchase a Cooperative-approved 200-amp meter base with main breaker independently. The member is responsible for installation to Cooperative's specifications.
- B. Cooperative shall furnish and install conductors to terminate at pipe mast.
- C. Member will furnish and install guy wires if required. Guy wires are required for pipe mast over 36" to a maximum of 60".
- D. Maximum height allowed above roof is 24"-36" unguyed and 36"-60" guyed allowed per NEC requirements. Member shall furnish and install line side galvanized steel rigid conduit, complete with weather heads, straps, and conductors.
- E. Member shall furnish and install load side conductor and Schedule 80 PVC conduit.
- F. Member shall furnish and install load conductors and connectors.
- G. The member shall furnish and install two 5/8" x 8" copperclad steel ground rods with approved clamps. Top of rods shall be at least 12" below grade level.
- H. The grounding electrode conductor from the ground rods shall not be spliced or terminated in the meter socket or utility portion of the pedestal. The top of the ground rods should be at least 12" below grade level. Ground wire shall be minimum 4 AWG copper wire.
- I. Member shall furnish and install a disconnecting means, which shall be located on the load side of the meter base.
- J. Wiring shall be installed in compliance with the state electrical code and any local requirements.



Price Electric Cooperative

A Touchstone Energy® Cooperative

200-Amp Overhead Service on Building/Overhead Pipe Mast

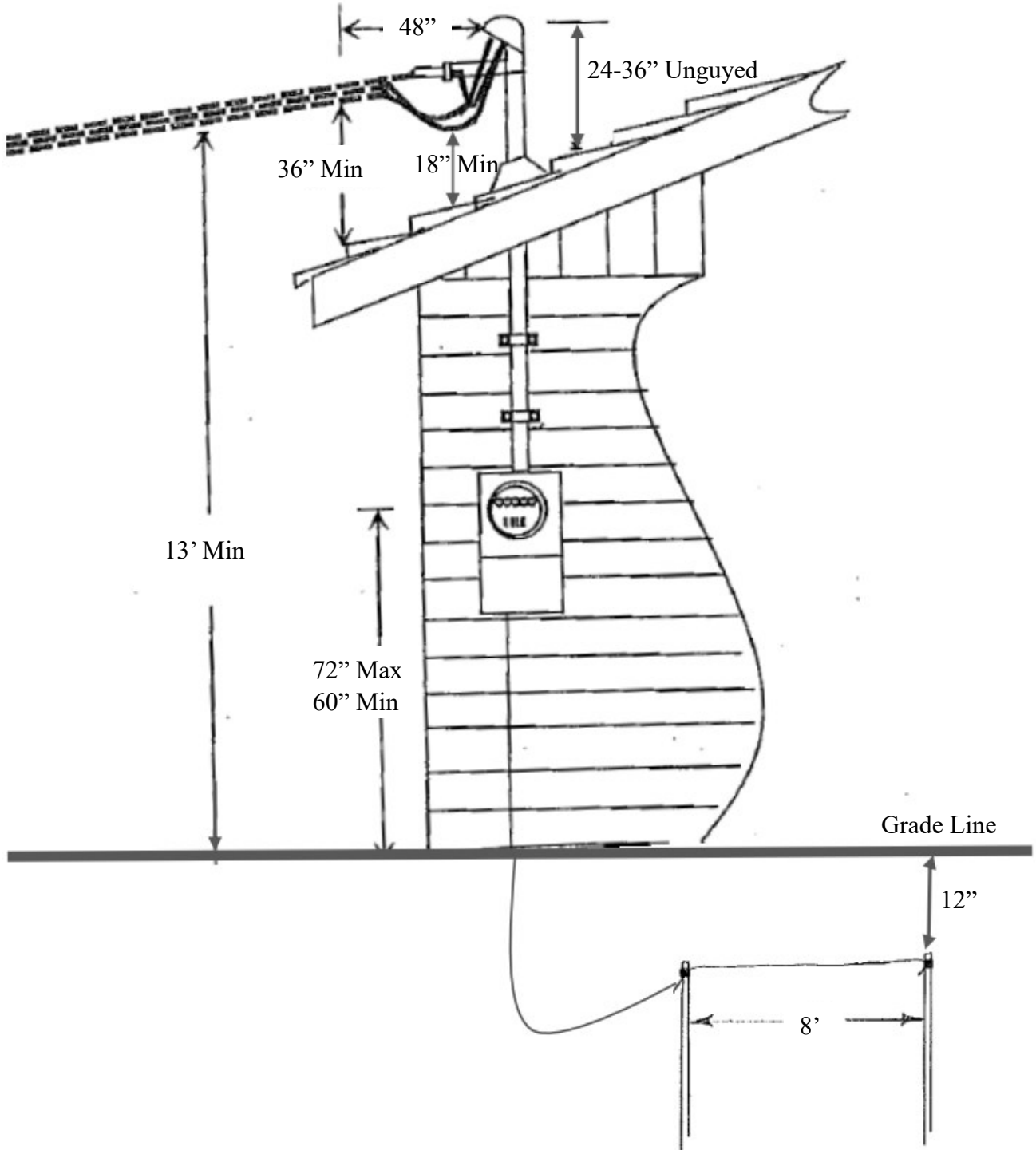



Price Electric Cooperative

A Touchstone Energy® Cooperative 

200-amp Overhead Gable End of House Service

- A. The member has the option to purchase a Cooperative-approved 200-amp meter base with main breaker independently. The member is responsible for installation to Cooperative's specifications.
- B. Cooperative shall furnish and install conductors to terminate at gable end of house. Member responsible for acceptable placement to meet required clearances for Cooperative to attach service.
- C. Cooperative shall furnish and install conductors to terminate at service entrance.
- D. Member shall furnish and install load side conductors.
- E. Member shall furnish and install 2" rigid galvanized steel or Schedule 40 PVC, complete with weather heads, straps, and conductors.
- F. Member shall furnish and install a disconnecting means, which shall be located on the load side of the meter base.
- G. The member shall furnish and install, two 5/8" X 8' copper clad steel ground rods with approved clamps. Top of rods shall be at least 12" below grade level.
- H. Wiring shall be installed in compliance with the state electrical code and any local requirements.



**Price Electric
Cooperative**

A Touchstone Energy® Cooperative

200-amp Overhead Gable End of House Service

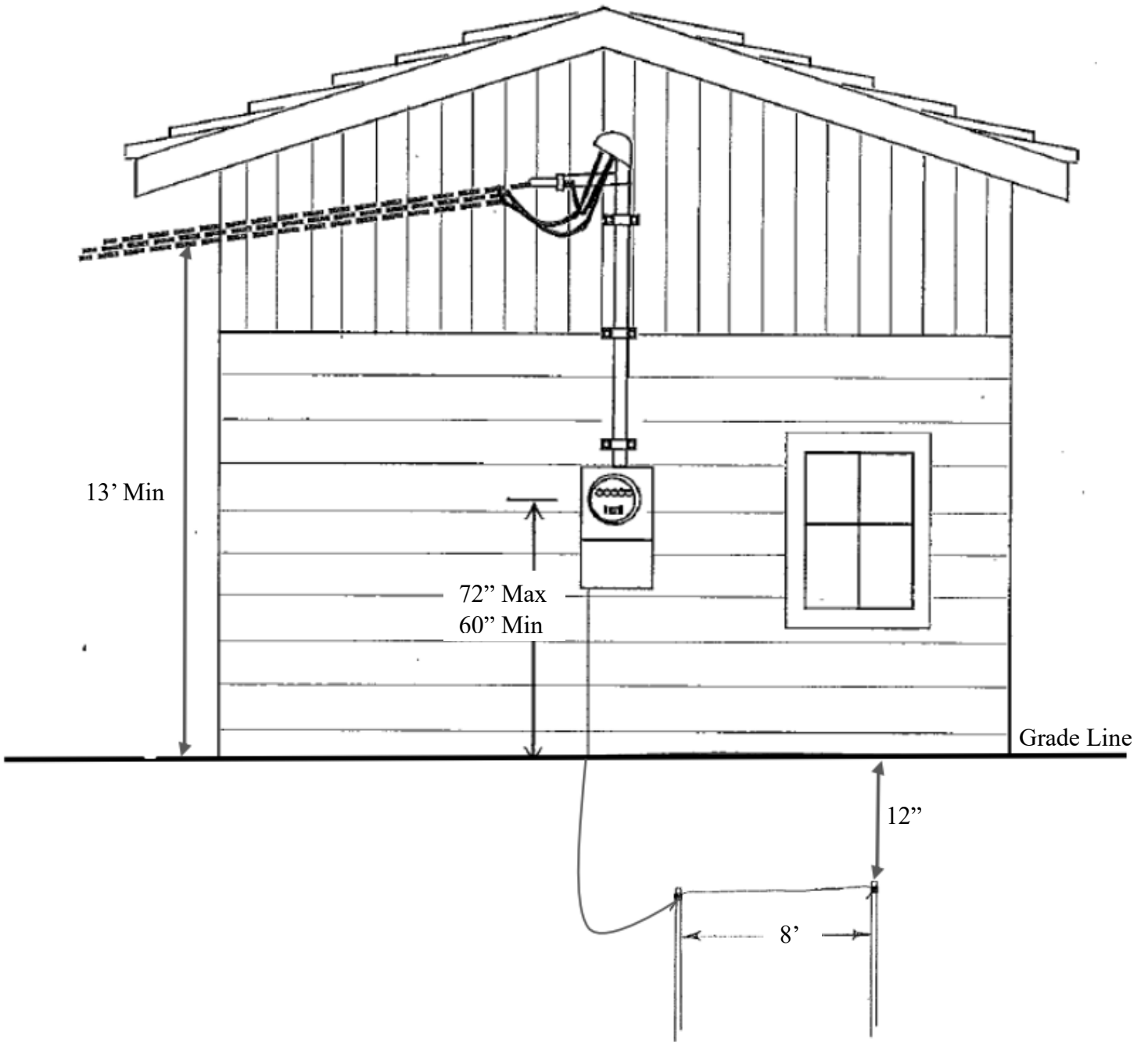



Price Electric Cooperative

A Touchstone Energy® Cooperative 

200-Amp Overhead to Underground Service, Pole Mounted

- A. The Cooperative shall furnish and install, at the expense of the member, a minimum 30-foot pole.
- B. Cooperative shall furnish and install conductors to terminate at meter pole.
- C. Cooperative shall furnish and install connectors to connect the Cooperative's conductors to the member's conductors.
- D. Member shall furnish and install line side conductors within 2" minimum Schedule 40 PVC conduit and pipe mast head.
- E. The member has the option to purchase a Cooperative-approved 200-amp meter base with main breaker independently. If purchased from the Cooperative, the Cooperative will install the base, at member expense. If purchased elsewhere, the member is responsible for installation to the Cooperative's specifications.
- F. Member shall furnish and install two 5/8" x 8' copperclad steel ground rods with approved clamps. The top of rods shall be at least 12" below grade level.
- G. Wiring shall be installed in compliance with the state electrical code and any local requirements.



**Price Electric
Cooperative**

A Touchstone Energy® Cooperative

200-Amp Overhead to Underground Service, Pole Mounted

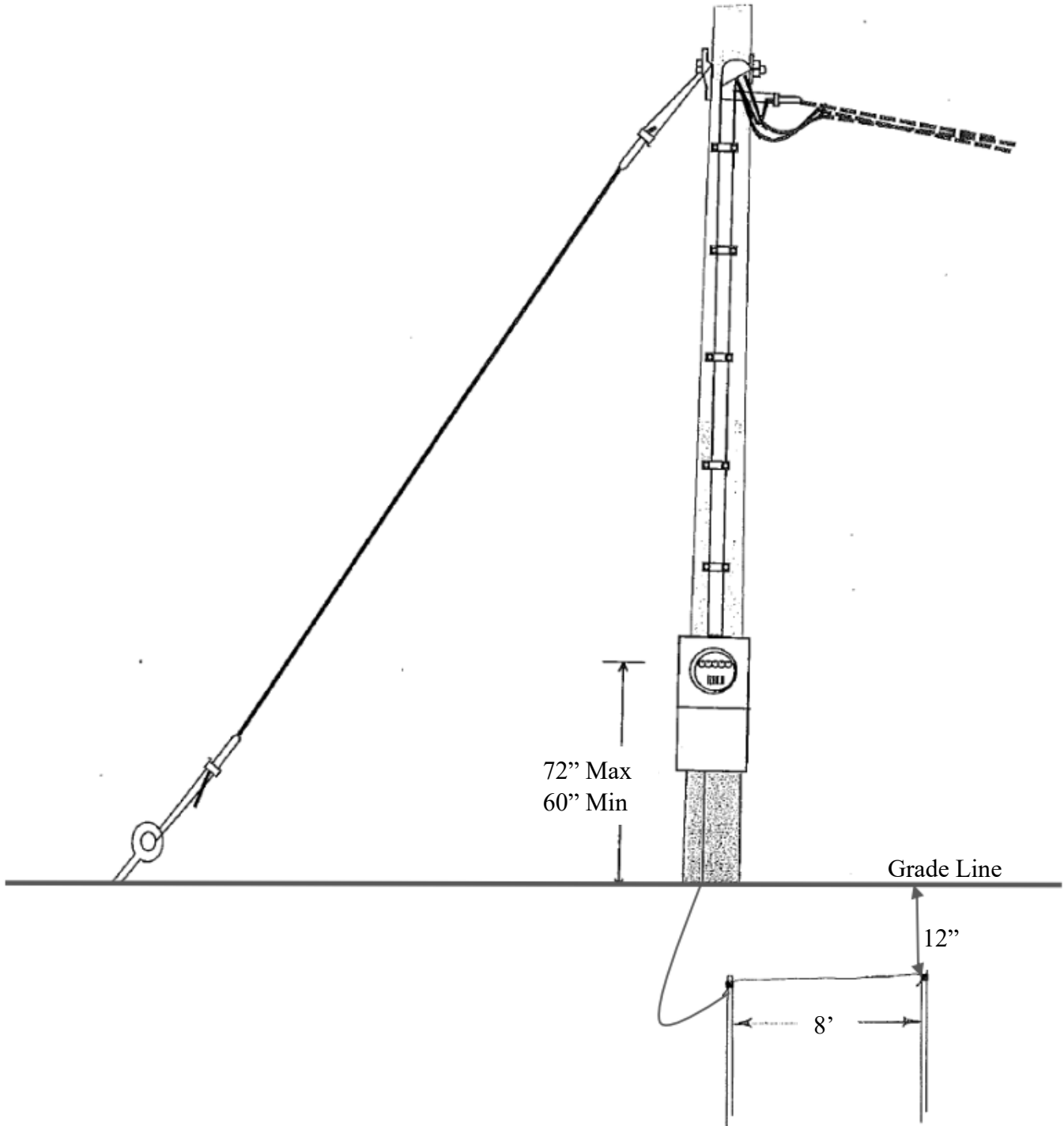



200-Amp Underground Structure-Mounted Meter Base

The Cooperative shall furnish and install the line conductors. Where the Cooperative's wires will be covered by concrete or blacktop, the member shall provide conduit to extend at least 3 feet beyond the edge of the concrete or blacktop.

The adequate size and type of conduit will be determined by the Cooperative and the conduit and trench must be inspected by the Cooperative prior to backfilling. Failure to do so could cause complications associated with the service installation and/or additional expense.

- A. The member has the option to purchase a Cooperative-approved 200-amp meter base with main breaker from the Cooperative or independently. The member is responsible for installation to Cooperative's specifications.
- B. Member shall furnish and install load conductors between the meter base and the disconnecting means.
- C. Rods shall be two 5/8" copper clad steel ground rods and approved clamps. Ground rods and grounding conductors shall not be installed in front of the meter pedestal or within 2 feet of the underground cable route. If the meter base and rods are purchased from the Cooperative, the Cooperative will install the rods and clamps. If purchased elsewhere, the member is responsible for installation to Cooperative specifications.
- D. The grounding electrode conductor from the ground rods shall not be spliced or terminated in the meter socket or utility portion of the pedestal. The top of the ground rods should be at least 12" below grade level. Ground wire shall be minimum 4 AWG copper wire.
- E. Adequate space shall be provided for removal of the meter pedestal cover when concrete or blacktop covers the area in front of the meter pedestal.
- F. A PVC slip joint will be installed on the lineside of the service installation.
- G. No meter base shall be installed under any windows.
- H. Wiring shall be installed in compliance with the state electrical code and any local requirements.



**Price Electric
Cooperative**

A Touchstone Energy® Cooperative

200-Amp Underground Structure-Mounted Meter Base

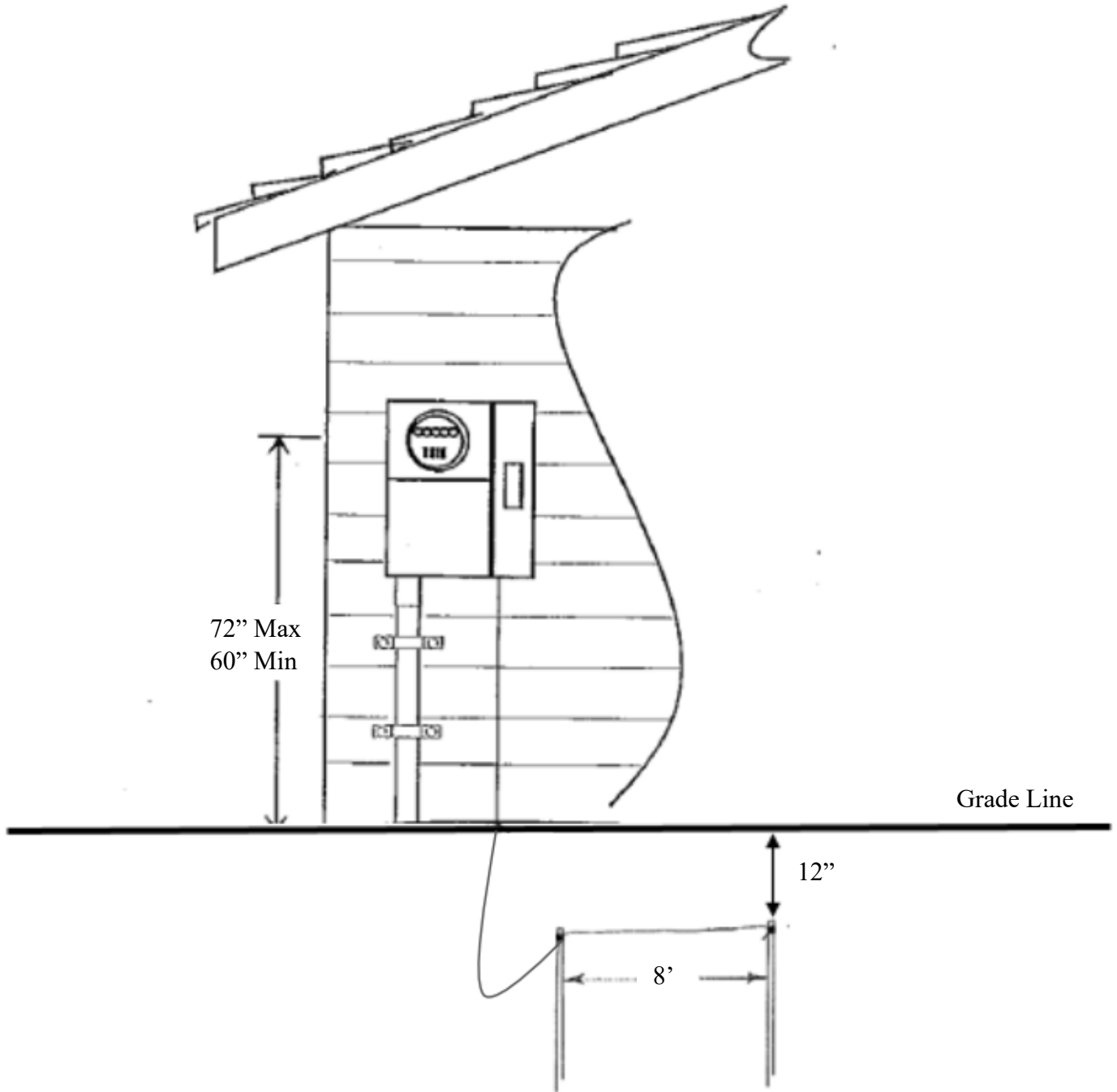



Price Electric Cooperative

A Touchstone Energy® Cooperative 

200-Amp Underground Structure, Mounted Meter Pedestal

The Cooperative shall furnish and install the line conductors. Where the Cooperative's wires will be covered by concrete or blacktop, the member shall provide conduit to extend at least 3 feet beyond the edge of the concrete or blacktop.

Adequate conduit will be determined by the Cooperative and the conduit and trench must be inspected by the Cooperative prior to backfilling. Failure to do so could cause complications associated with the service installation or additional expense.

- A. The member has the option to purchase a Cooperative-approved 200-amp meter pedestal with main breaker from the Cooperative or independently. The member is responsible for installation to Cooperative's specifications.
- B. If the member purchases a Cooperative-approved 200-amp meter base with main breaker from the Cooperative, the Cooperative-approved ground rods will be supplied. The rods shall be two 5/8" copper clad steel ground rods and approved clamps. Ground rods and grounding conductors shall not be installed in front of the meter pedestal or within 2 feet of the underground cable route. The member is responsible for installation to Cooperative specifications.
- C. The grounding electrode conductor from the ground rods shall not be spliced or terminated in the meter socket or utility portion of the pedestal. The top of the ground rods should be at least 12" below grade level. Ground wire shall be minimum 4 AWG copper wire.
- D. Member shall furnish and install load conductors between the meter pedestal and the disconnecting means.
- E. Adequate space shall be provided for removal of the meter pedestal cover when concrete or blacktop covers the area in front of the meter pedestal.
- F. Wiring shall be installed in compliance with state electrical code and any local requirement.



**Price Electric
Cooperative**

A Touchstone Energy® Cooperative

200-Amp Underground Structure, Mounted Meter Pedestal

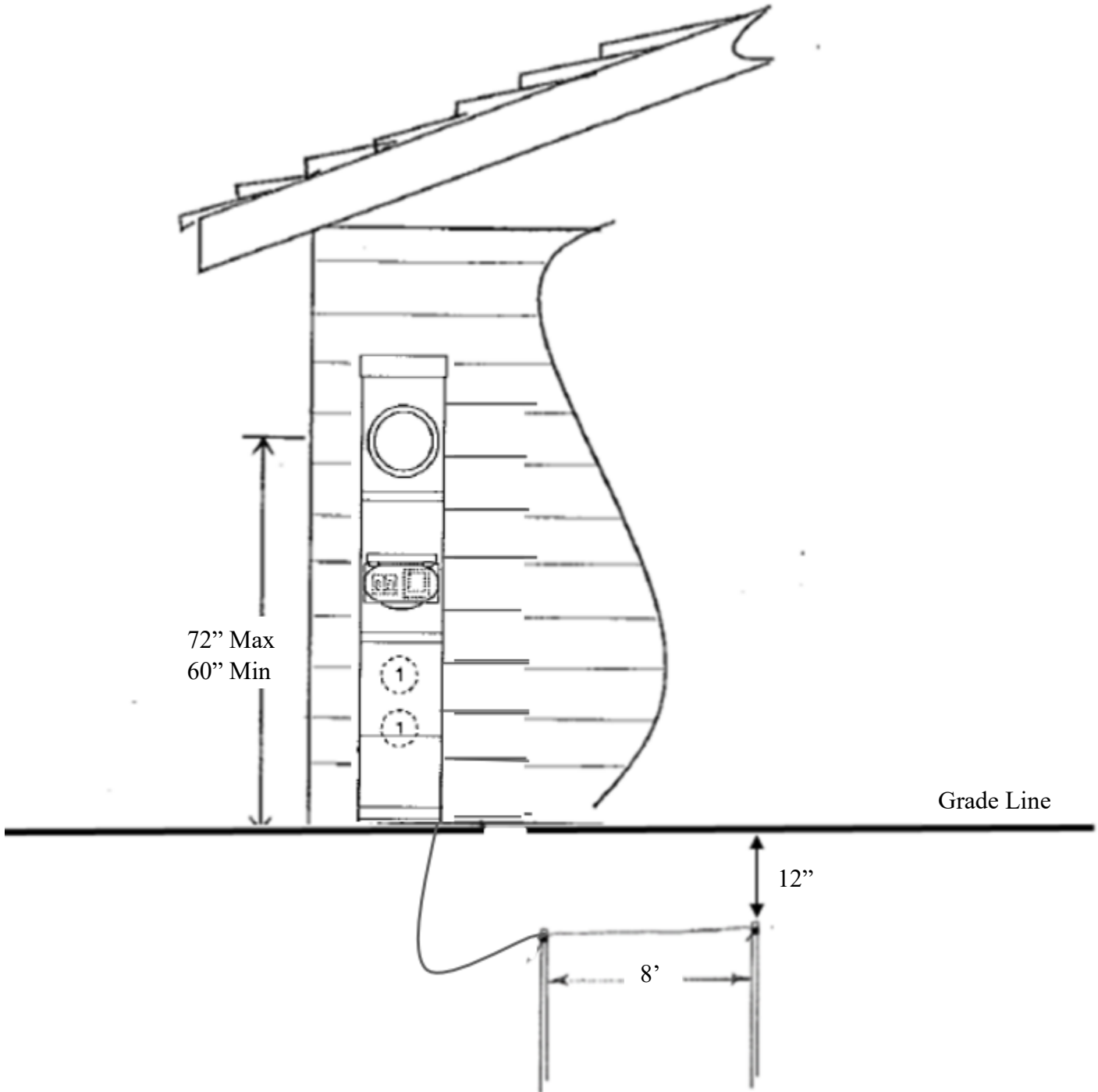



Price Electric Cooperative

A Touchstone Energy® Cooperative 

400-Amp Single Phase Underground Service

- A. Cooperative shall furnish and install current transformers.
- B. Cooperative shall furnish and install metering conductors.
- C. Cooperative shall furnish and install underground line conductors.
- D. If mounted remotely, the member shall furnish and install treated posts and backboard, or other support structure approved by the Cooperative. Treated wood posts of 6" x 6" nominal dimension and treated plywood 4' x 4' and of 3/4" minimum thickness will meet minimum requirements.
- E. Member shall furnish and install a Cooperative approved current transformer enclosure and all connecting conduit. (See "Approved Equipment List")
- F. Member shall furnish and install 3" minimum Schedule 80 PVC conduit to extend a minimum of 18" below finished grade.
- G. Member shall furnish and install load conductors and supply lugs for meter base.
- H. Member shall furnish and install grounding conductor and conduit.
- I. Member shall furnish and install two 5/8" copper clad steel ground rods and approved clamps. Ground rods and grounding conductors shall not be installed in front of the meter base or within 2 feet of the underground cable route. Ground wire shall be minimum 2 AWG copper wire.
- J. Member shall furnish and install the ground wire jumper conductor from the neutral busbar to the enclosure itself with approved bonding clamps and minimum of 2/0copper-stranded conductor.
- K. Wiring shall be installed in compliance with the state electrical code and any local requirements.



Price Electric Cooperative

A Touchstone Energy® Cooperative

400-Amp Single Phase Underground Service

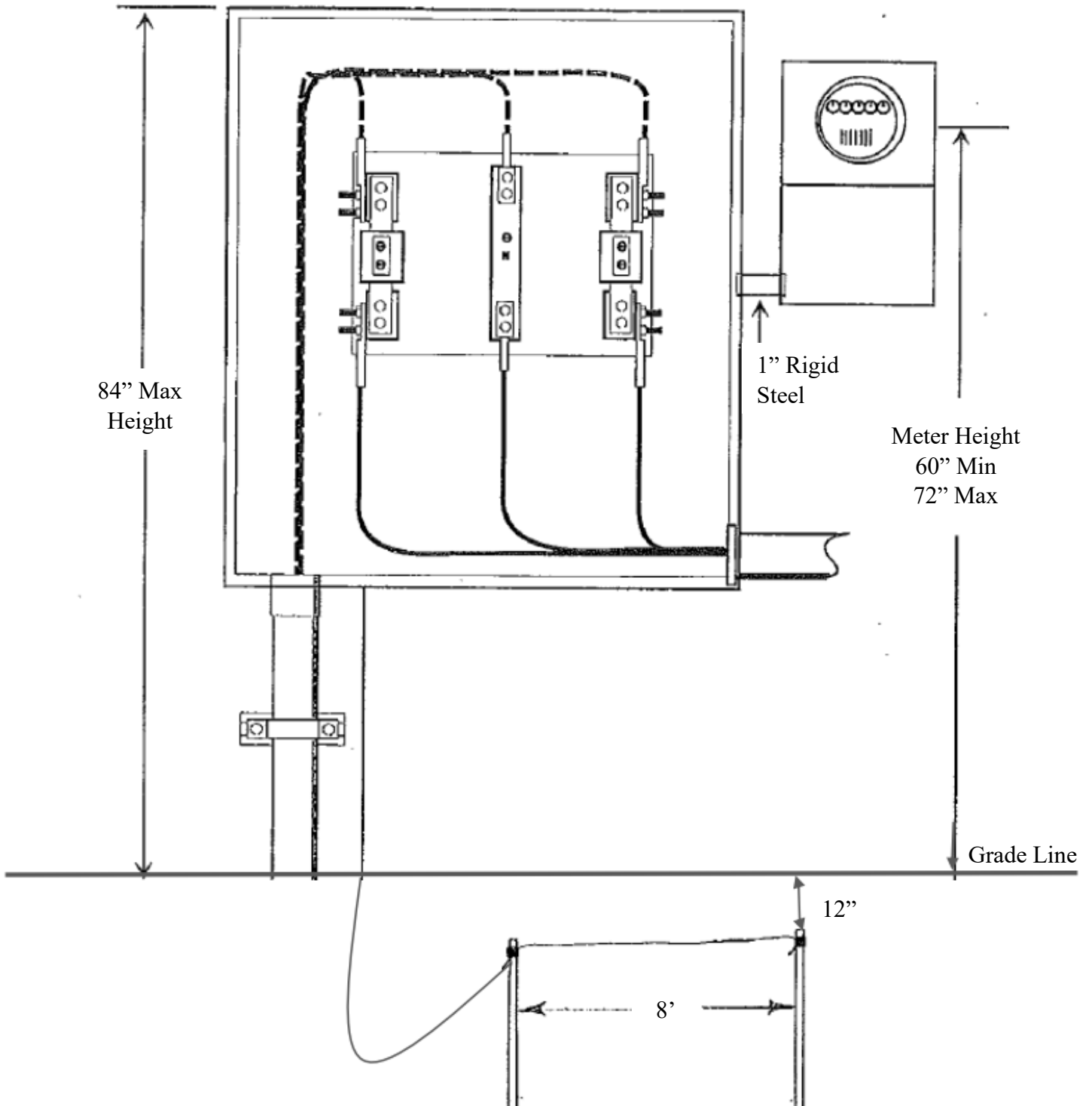



**Price Electric
Cooperative**

A Touchstone Energy® Cooperative 

400-Amp Single Phase Underground Service





Price Electric Cooperative

A Touchstone Energy® Cooperative 

400-Amp & Above Three-Phase Underground Service

- A. The Cooperative shall furnish and install current transformers.
- B. Cooperative shall furnish and install underground line conductors.
- C. Member shall furnish and install a Cooperative approved current transformer enclosure and all connecting conduit. (See “Approved Equipment List”)
- D. Member shall furnish and install Schedule 80 PVC conduit specified by
- E. Cooperative and this conduit or conduits are to extend a minimum of 18” below finished grade.
- F. Member shall furnish and install line and load conductors and connectors.
- G. Member shall furnish and install grounding conductor and conduit.
- H. Member shall furnish and install two 5/8” x 8’ copper clad steel ground rods with approved clamps. Ground rods and grounding conductors shall not be installed in front of the meter base or within 2 feet of the underground cable route. The top of rods should be at least 12” below grade level. Ground wire shall be minimum 2 AWG copper wire.
- I. Member shall furnish and install the ground wire jumper conductor from the neutral busbar to the enclosure itself with approved bonding clamps and a minimum of 2/O copper-stranded conductor.
- J. Cooperative shall furnish and install, at member expense, the meter base with test switches per the “Approved Equipment List”.
- K. Wiring shall be installed in compliance with the state electrical code and any local requirements.



Price Electric Cooperative

A Touchstone Energy® Cooperative

400-Amp & Above Three-Phase Underground Service

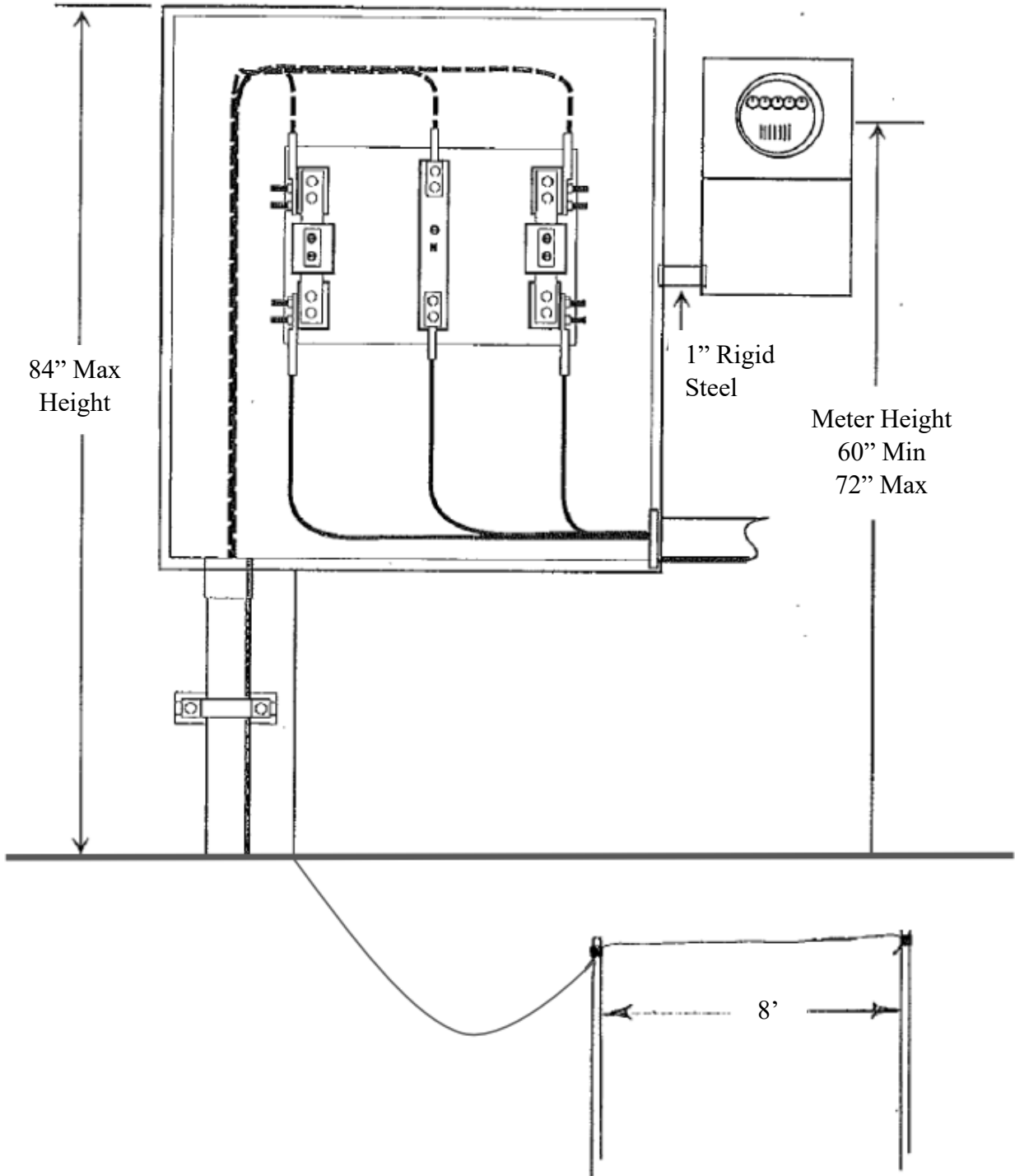



Price Electric Cooperative

A Touchstone Energy® Cooperative 

200-Amp Underground Service, Meter/Transfer Switch Combo, Backboard Mount

- A. The Cooperative shall install a meter/transfer switch combination, at the expense of the member.
- B. The Cooperative shall furnish and install a 6x6 backboard with 5/8 backing, at the expense of the member.

Need more information/details for this section



**Price Electric
Cooperative**

A Touchstone Energy® Cooperative 

Section 7—Member Generating Equipment

Standby Generating Equipment

The Cooperative shall be consulted before any generating equipment is connected to any circuits which are or may be supplied from Cooperative's service lines. The member shall install an approved double pole / double throw (transfer) switch that is mechanically interlocked—(of adequate current and voltage rating) so that the connected member's generating equipment cannot energize the Cooperative's supply lines.

The double pole / double-throw (transfer) switch may be manually or automatically operated. Member-owned generating equipment shall not operate in parallel with the Cooperative's system except under specific contract with the Cooperative covering the conditions of such operation.

Distributed Generation System, Alternate Power and/or Parallel Generation

A parallel generation system allows the transfer of electrical energy from the member's generator in the Cooperative's distribution system. Consult the Cooperative for the requirements of this service.



**Price Electric
Cooperative**

A Touchstone Energy® Cooperative 

Appendix

Minimum Wire Size and Service Ratings

Ref. NEC Table 310-15 (B)(7)

Conductor Types and Sizes for 120/240 Volt, 3 wire, Single Phase Dwelling Services and Feeders.

Conductor Types: RHH, RHW, RHW-2, THHN, THHW, THW-2, THWN, THWN-2, XHHW, XHHW-2, SE, USE, USE-2

Conductor (AWG or kcmil) Service or Feeder Ratings (amps)	Copper	Aluminum or Copper Clad Aluminum
200	2/0	4/0
300	250	350
350	350	500
400	400	600

A minimum of 200 ampere, three wire service shall be installed for all dwellings.



**Price Electric
Cooperative**

A Touchstone Energy® Cooperative 

Minimum Wire Size for Underground Services Larger than 400 amps

Ref. NEC 2011 Table 310.15(B)(16) (formerly Table 310.16)

Conductor Types and Sizes for Underground Services and Feeders.

Conductor Types: RHW, THHW, THW, THWN, XHHW, USE. No more than three current-carrying conductors per conduit.

Meter Cabinet Rating (amps)	Service Entrance Conductor Size (75C Copper)	2011 NEC Table 310.15(B)(16) 75C Ampacity per run	Number of Runs	Total Ampacity
400	3/0	200	2	400
	4/0	230	2	460
600	3/0	200	3	600
	4/0	230	3	690
800	350	310	3	930
	500	380	3	1140
1200	350	310	4	1240
	500	380	4	1520
	750	475	3	1425
1600	350	310	6	1860
	500	380	5	1900
	750	475	4	1900
2000	350	310	7	2170
	500	380	6	2280
	750	475	5	2375
2500	500	380	7	2660
	750	475	6	2850
3000	500	380	8	3040
	750	475	7	3325

Rigid Conduit

Rigid conduit includes rigid galvanized steel, rigid aluminum, galvanized IMC or rigid nonmetallic conduit Schedule 80 PVC electrically rated and Schedule 80 equivalent polyethylene. The rigid nonmetallic conduit shall conform to specifications in Articles 342,344, and 352 of the National Electric Code. “Galvanized steel conduit” may be either rigid steel or galvanized intermediate metal conduit (IMC). It shall not be electric metallic tubing (EMT).



Price Electric Cooperative

A Touchstone Energy® Cooperative

The tables below are a general guide to determine the conduit sizes and number for the services listed. The sizes and numbers of these facilities may have to be modified to take into account the length of the lateral, customer load, and voltage drop considerations.

Underground Single Phase-Main Service Disc. Amps	Min. Number of Conduits	Conduit Size	Min. Radius Bend Galvanized Steel	Min. Radius Bend Rigid Non-Metallic
200	1	2"*	9 ½"	18"
300	1	3"	13"	24"
400	2	4"	16"	30"
600	3	4"	16"	30"
800	3	4"	16"	30"

*A 2 ½ inch conduit may be required if larger conductors are required. Check with the Cooperative before installing service conduit.

Underground Three Phase-Main Service Disc. Amps	Min. Number of Conduits	Conduit Size	Min. Radius Bend Galvanized Steel	Minimum Radius Bend Rigid Non-Metallic
200	2	3"	13"	24"
300	2	4"	13"	24"
400	3	4"	16"	30"
600	4	4"	16"	30"
800	4	4"	16"	30"
1200	6	4"	16"	30"
1600	7	5"	24"	36"
2000	7	5"	24"	36"
2500	8	5"	24"	36"
3000	9	5"	24"	36"

Notes, For both the Single Phase and Three Phase Tables:

- All PVC conduit elbows shall be pre-formed.
- For longer conduit runs containing 3 or more bends, the customer shall consult with PEC for conduit size, and for the radius bend to use.

Capacity, Disconnects, Fault Current Ratings, and Ground Fault Protection

Determination of minimum fault current ratings for member’s disconnects and breakers:

The minimum fault current rating is not determined by the size of the member’s service, rather, it is a property of the transformer that the service is connected to.

Outdoor Location of Pad Mount Transformers Near Buildings

All pad mounted transformers will be located a minimum of 10 feet from any building wall unless a proper fireproof barricade is installed. (Wisconsin Administrative Code PSC 114-317)



Price Electric Cooperative

A Touchstone Energy® Cooperative 

Overhead Conductor Clearances

Triplex wire vertical clearances, 0-750 volts to:

- Railroad tracks- 24ft
- Roads, streets, alleys- 17ft
- Driveways, parking lots- 16ft
- Land that could have vehicular traffic- 16ft
- Land with restricted traffic- 12ft
- Water, ponds, streams, etc.-14ft-37.5ft (consult electrician)
- Swimming pools- 22.5ft
- Roofs not readily accessible- 18in drop loop/36in service conductor
- Roofs not readily accessible more than 6ft from mast- 3ft
- Roof not readily accessible crossing not attached to mast- 3.5ft
- Signs, chimneys, antennas- 3.5ft
- Propane, gasoline tanks- Per PSC 114
- Lines near wells- 10ft

These are minimum clearances for low voltage lines only. Contact the Cooperative for assistance and more detailed information or for voltages over 750.

Approved Equipment List

200 Amp Single Phase Freestanding Pedestal

- Milbank U5136-0-200S-10GR-WI (Single Meter Socket)
- Milbank U5137-0-200S-10GR-WI (Dual Meter Socket)
- Building--Milbank NU8980-O-200-KK

320 Amp Single Phase Freestanding Pedestal

- Durham 1009282 Pre-wired; Durham 1009922, 12" extension; Durham ARP01066
- Building--Milbank U3849-O-2/200
- Building--Milbank U1748-O-WI

Current Transformer Enclosure

- Cooper Industries 363611 RTCT (400 amperes)*
- Cooper Industries 424211 RTCT (600-1400 amperes) *

*Metering current transformer mounts will be specified by the Cooperative depending on ampere rating and service type.



Price Electric Cooperative

A Touchstone Energy® Cooperative 

Meter Sockets

4 Terminal 200 Amp w/load center

- Milbank U5871-XL-200-K1 (lever bypass)
- Milbank U4322-O-5T9 200 Amp
- Milbank R5168-XTL-200-KK
- Multi service 4 position U5884-X-KK-K16 position U5886-X-KK-K1
- Eaton Type CH CMBX1212B200BTS

5 Terminal 320 Amp

- Milbank U5059-X-2/200-K3L
- Milbank U5894-X-2/200
- Milbank U5893-X-2/200
- Milbank U2448-X NOTE: add connector size #6-350; requires a disconnect after the base

5 Terminal 400 Amp Single Phase

- Ronk 7406MS-X (Extra deep/wide w/ DPDT switch for generator use)

7 Terminal Three Phase w/bypass

- Milbank U9761-RRL

13 Terminal 20 Amp w/test switches

- Milbank UC7445-XL-TS100109
- Durham ASTS 13-1C480

Multiple Position Sockets

4 Terminal 200 Amp per position/2 positions

- Milbank U1252-X

*Contact Price Electric for clarification or standards for meter sockets mentioned or possibly not mentioned.



**Price Electric
Cooperative**

A Touchstone Energy® Cooperative 

Glossary

A

AC: The abbreviation for alternating current.

ACCESS, ACCESSIBLE: “Access” means capability of being reached quickly for operating, reading, repairing, removing, testing, inspecting, or installing meters, transformers, switches, conductors, electrical enclosures, and related equipment without requiring those for whom access is required to climb over or remove obstacles, to unlock doors, to dismantle fences or gates, and so forth. Accessible equipment is not guarded by architectural enhancements, dogs, elevation, locks, parked vehicles, structures, or other impediments.

ACCESS OPENING: The minimum opening of a pull section or termination enclosure required for utility work access. This opening is measured from the edge of flange to the edge of flange, not from sidewall to sidewall.

AIC: As used in this book is defined as the Ampere Interrupting Capacity (AIC), sometimes referred to as the Ampere Interrupting Rating (AIR) of meter disconnects, service disconnects, main service disconnects, and other service entrance equipment. AIC ratings are sometimes applied to the mechanical bracing of conductors or bus of service entrance equipment such as CT mounting bases or switchboard service sections. Also see **INTERRUPTING RATING**.

AEIC: Association of Edison Illuminating Companies.

AMPACITY: The current expressed in amperes that an electric conductor can carry continuously under specified conditions of use without exceeding its temperature rating.

AMPERE (Amp): The practical unit of electric current. One (1) ampere is the current caused to flow through a resistance of one (1) ohm by one (1) volt.

ANSI: American National Standards Institute.

APPROVED: As used in these requirements, the term “approved” means authorized, sanctioned, permitted, or specified by the Utility. In most cases, the approval will be in written or published form.

AUTOMATIC BYPASS: A device within a meter socket that automatically operates upon removal of the meter from the socket allowing current to flow from the Utility’s (line-side) socket clips to the customer’s (load-side) socket clips with the meter removed from the socket.

AWG: American Wire Gauge, a term used to measure wire size.

B

BILLING METERING: Electricity meters, recorders and associated devices used by the Utility to measure electric energy consumed by the customer as necessary to implement a given rate schedule.

BONDING (BONDED): The permanent joining of metallic parts to form an electrically conductive path which will assure electrical continuity and the capacity to conduct safely any current likely to be imposed.



Price Electric Cooperative

A Touchstone Energy® Cooperative

BREAKER: Customer's circuit breaker. See **CIRCUIT BREAKER**.

BUS, LAMINATED: More than one bus bar per phase, connected in parallel.

BUS, LIVE: Bus bars which are normally energized.

BUS, REMOVABLE LINK: Used in a CT compartment to link the line and load bus together. This removable section of bus is designed to allow the installation or removal of CTs.

BUS STUBS: The part of a bus bar reserved for the termination of conductors.

BUSHINGS: Plastic or nylon rings that attach to the ends of conduit to protect the electrical cable from sharp edges.

BYPASS: A device which shunts current around the meter socket so the meter can be removed without interrupting service to the customer. Also see **TEST-BLOCK BYPASS**.

C

CIRCUIT BREAKER: A device designed to open and close a circuit by non-automatic means and to open the circuit automatically on a predetermined over-current without damage to itself when properly applied within its rating.

CONDUCTORS, LINE-SIDE (SUPPLY-SIDE): See **CONDUCTORS, UN-METERED**.

CONDUCTORS, LOAD-SIDE: See **CONDUCTORS, METERED**. **CONDUCTORS, METERED:** Conductors transmitting electrical energy that has been

previously recorded by the Utility's billing meter.

CONDUCTORS, UN-METERED: Conductors transmitting electrical energy that has not been recorded by the Utility's billing meter.

CONDUIT: A listed or approved pipe with a smooth interior surface to permit easy drawing in of electrical conductors.

CONTINUOUS LOAD: A load where the maximum current is expected to continue for three hours or more.

CORFLO: A flexible duct made of synthetic material used as a conduit for electric cables. Corflo is used by the Utility to install underground service temporarily above ground. The Utility limits the use of corflo in above ground applications to secondary (less than 600 volts) service applications (corflo in above ground 480 volt applications is limited to restricted access areas that are not accessible to the public).

CT: An acronym for Current Transformer. The term CT and the phrase "Current Transformer" are synonymous terms. See **CURRENT TRANSFORMER**.

CT RATED METER: An electricity meter used in conjunction with current transformers to accurately measure and register all the electrical energy consumed in the circuit to which it is connected.



Price Electric Cooperative

A Touchstone Energy® Cooperative 

CURRENT: See AMPERE.

CURRENT TRANSFORMER: An instrument transformer designed for the measurement of current. It is used to reduce primary current by a known ratio to within the range of a transformer rated kilowatt hour meter. Current transformers are often referred to by the acronym CT.

CUSTOMER: Any person, persons, corporation, etc. or their designated representative, for whom the electric service and meter installation is provided.

D

DISCONNECT DEVICE: A device whereby the conductors of a circuit can be disconnected from their source of supply (IEEE 100-1984).

DISCONNECTING MEANS: A device or group of devices or other means by which the conductors of a circuit can be disconnected from their source of supply.

DRIP LOOP: A downward loop in the customer's conductors adjacent to the Utility's conductors to prevent water from entering the service mast at the weather head.

E

ELECTRODE: A solid electric conductor through which an electric current enters or leaves. As used in this book, the term refers to a grounding electrode. See **GROUNDING ELECTRODE**.

ENCLOSURE: Box-like structure designed to enclose and protect utility service conductors or equipment.

G

GROUND: A conducting connection, whether intentional or accidental, between an electric circuit or equipment and earth.

GROUNDING: As used in this book, it means intentionally connected to earth through a ground connection or connections of sufficiently low impedance and having sufficient current-carrying capacity to prevent the buildup of voltages that may result in undue hazards to connected equipment or to persons.

GROUNDING CONDUCTOR: A conductor used to connect any equipment device, or wiring system, with a grounding electrode or electrodes.

GROUNDING ELECTRODE: A conductor embedded in the earth, used for maintaining ground potential on conductors connected to it and for dissipating current conducted to it into the earth.

GROUNDING LUG: A lug designed for terminating the customer's grounding wire.

GUYING: Cables or braces used to relieve the strain of overhead conductors on masts and poles.



Price Electric Cooperative

A Touchstone Energy® Cooperative 

I

INSTRUMENT TRANSFORMER: A transformer that reproduces in its secondary circuit a definite and known ratio of the current or voltage of its primary circuit, with the phase relationship substantially preserved.

ISOLATING BARRIER: A partition of either conductive or non-conductive material used to mechanically isolate energized equipment from outside elements and/or to mechanically isolate compartments or sections from other integral sections or compartments of the enclosure.

L

LINE-SIDE CONDUCTOR: A service conductor delivering electrical power to the customer which has not been recorded by the Cooperative's meter.

LOAD-SIDE CONDUCTOR: Any conductor delivering electrical power to the customer which has been recorded by the Cooperative's meter.

LOCKABLE: Accepting a padlock with a shackle diameter of five-sixteenths (5/16)inch.

LUGS: Used to terminate cable conductors on termination facilities.

M

MAIN SERVICE DISCONNECT: A circuit breaker, fused switch, or other approved disconnecting means installed on the supply (line) side of an installation of seven or more meter sockets.

METER DISCONNECT: A circuit breaker, fused switch, or other approved service disconnecting means with overcurrent protection that controls all of, and only the energy registered by its related meter.

METER HEIGHT: Meter height is the distance measured from the center axis of the installed meter to the standing surface immediately in front of the meter.

METER JAW: A spring-loaded receptacle inside a meter socket which captures the terminals (blades) of a meter and connects the meter terminals to the service conductors.

METER PANEL: Panel used exclusively for mounting meter sockets and associated equipment.

METER PEDESTAL: Free standing meter enclosure, typically used for commercial applications.

METER SEQUENCE: The sequential relation between the service switch and the billing meter in a series arrangement. The term **NEW SEQUENCE** means a meter-switch-fuse sequence. **OLD SEQUENCE** means a switch-fuse-meter sequence.

METER SOCKET: The mounting device consisting of meter jaws, connectors, and enclosure for accommodating socket-type meters.

MULTIPLE METERING: Prefabricated service entrance equipment consisting of a service termination section and two or more meter sockets.



Price Electric Cooperative

A Touchstone Energy® Cooperative 

N

NEC: The most recent State adopted publication of the National Electrical Code.

NEMA: National Electrical Manufacturers Association

NESC: The most recent State adopted publication of the National Electrical Safety Code

NET METERING: Metering for the receipt and delivery of electricity between a producer and the Utility pursuant to RCA rules. Over a given time frame (typically a month) the difference between these two values yields either NET consumption or surplus. See Section 214.

P

PLUMB: In this case referring to the meter socket enclosure. To have the sides and front of the meter socket enclosure perfectly vertical from both the front and side views.

POINT OF SERVICE: The point where the load or customer's conductors or those of their respective agents meet the Cooperative's electric power system (point of ownership change).

PRIMARY: Service voltage greater than 600 volts.

R

RACEWAY: An enclosed channel designed expressly for holding wire, cables or bus bars. If designated for line-side conductors, it shall be sealable. The intermixing of line-side and load-side conductors in the same raceway is not permitted.

S

SECONDARY: Service voltage less than 600 volts.

SELF-CONTAINED METER: A meter that carries the entire load current and is energized at line voltage.

SERVICE: Electric service from the Utility's electric distribution system to the electrical equipment of the customer's facilities.

SERVICE DISCONNECT: A circuit breaker, fused switch, or other approved disconnecting means by which the service conductors can be disconnected from the utility source of supply. The term "Service Disconnect" can be used to describe a disconnect device installed on the supply (line) side of more than six meters also referred to as a main service disconnect. The term "Service Disconnect" can also be used to describe a meter disconnect which controls all, and only the energy registered by its related meter. See MAIN SERVICE DISCONNECT and see METER DISCONNECT.

SERVICE EQUIPMENT: As used in this book, the term "service equipment" refers to meter sockets, meter socket enclosures, meter panels, multi-meter panels, service conductor termination compartments, pull boxes for service conductors, pull sections for service conductors, CT cabinets, CT compartments of switchboards, bus spacers, service disconnects, meter disconnects, main service disconnects, grounding electrodes, grounding electrode



Price Electric Cooperative

A Touchstone Energy® Cooperative 

conductors, and any other equipment or enclosures related to the supply and metering of electric service from the Utility's system to a customer's premises. For the purposes of this book, the terms "service equipment" and "service entrance equipment" are synonymous terms.

SWITCH: A device for making, breaking, or changing the connections in an electric circuit.

T

TEST SWITCH: An arrangement of small knife switches connected in the secondary current transformer circuit between the instrument transformers and associated meters and metering devices. The test switch is used by the Utility to isolate the metering from the instrument transformers. Also referred to as a meter test switch.

U

UL: Underwriters Laboratory.

V

VISIBLE OPEN: As used in this book, the term refers to an electrical disconnect device where an actual physical break in the electric circuit is observable without resorting to extraordinary means.

VOLT: The practical unit of electromotive force, or potential difference. One volt will cause one ampere to flow when impressed across a one ohm resistor.

VOLTAGE TRANSFORMER (VT): An instrument transformer designed for the measurement of voltage. It is used to reduce primary voltage by a known ratio to within the range of a transformer rated kilowatt hour meter.

W

WATT: The practical unit of active power which is defined as the rate at which energy is delivered to a circuit. It is the power expended when a current of one ampere flows through a resistance of one ohm. A watt represents a unit of real electric power as contrasted with a volt-ampere which represents a unit of apparent power.

WATTHOUR: The practical unit of electric energy which is expended in one hour when the average power during the hour is one watt.

WATTHOUR METER, CT RATED: An electricity meter used in conjunction with current transformers to accurately measure and register all the electrical energy consumed in the circuit to which it is connected. The unit of measurement is the kilowatt hour.

WATTHOUR METER, SELF-CONTAINED: An electricity meter that measures and registers all the electrical energy consumed in the circuit in which it is connected and does not require instrument transformers. The unit of measurement is the kilowatt hour.